

Arch breaker & Metering unit ZFP 500 / DM



Waste water



Drinking water



Air & smoke

Powder discharge and dosing system for small capacity hopper :

The arch breaker and metering unit ZFP 500 / DM is a mechanical discharge and dosing system for bulk powders.

It can be installed under any storage hopper (volume between 50 to 3000 litres) and offers a compact powder dosing unit, adapted to the specific needs of each project.

The type of container (sack-tip hopper, buffer hopper or weighing hopper), chosen for the arch breaker and metering unit assembly, depends on the process of each project.

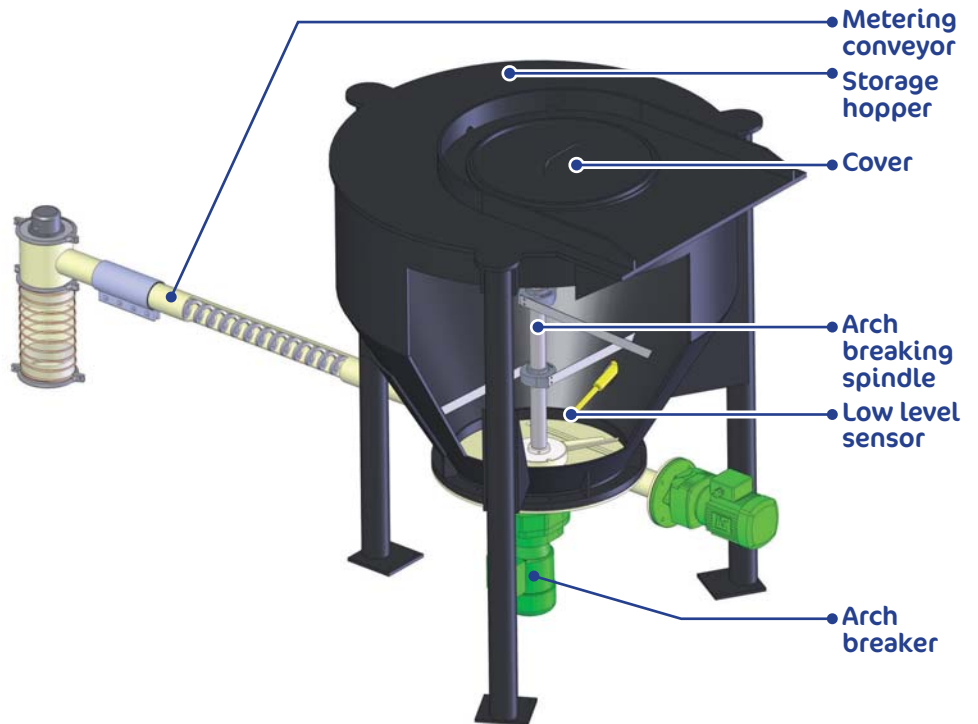

Examples of setting-up :

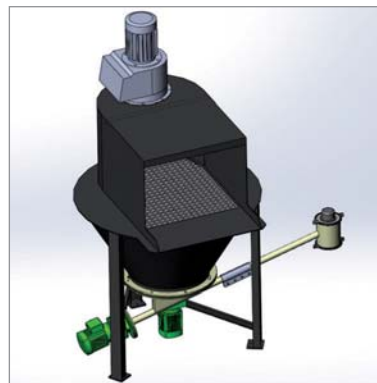

Sack-tip hopper

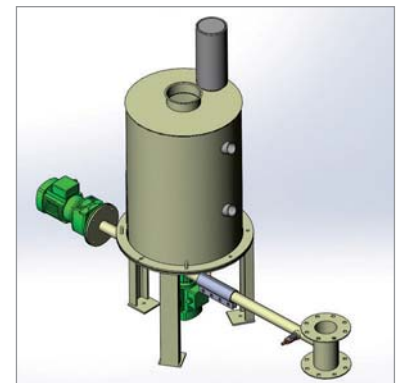

Buffer hopper

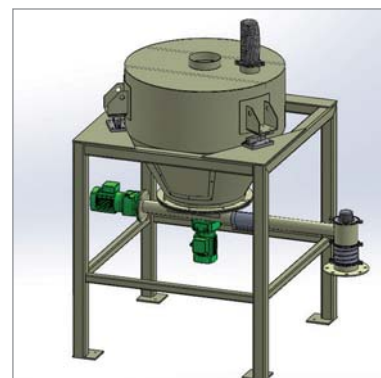

Weighing hopper

Advantages :

- Constant flow and accurate volumetric dosing
- Low power consumption
- Easy assembly onto transfer or injection system
- Mechanical discharge without product compaction or contamination
- Easy to assemble : adjustable length, flexible or rigid metering conveyor





Operation :

The main part of the arch breaker ZFP 500 is the arch breaking spindle.

It rotates inside the hopper cone thanks to a geared motor, allows its flexible blades to prevent the product from building an arch and ensures a constant flow.

The rigid arms, which are directly connected to the spindle, allow the metering conveyor to be fully filled of product in order to obtain an accurate volumetric dosage.



Specificities :

- **Metalwork material (carbon steel, stainless steel 304 / 316)**
- **Fixed or variable throughput**
- **Simple or double / Rigid or flexible metering conveyor**
- **Numerous discharge diameters (500, 800, 1000, 1250 mm)**

Example of dosed product	Maximum length of metering conveyor
Quick lime	4 m max.
Hydrated lime	7 m (depending on the throughput)
Activated carbon (PAC)	7 m (depending on the throughput)
Sodium bicarbonate	4 m max.
Microsand	2 m max.
Soda ash	4 m max.
Polymer	4 m max.
Other products	To be defined after sample analysis

Options :

- **Conveyor rotation sensor**
- **Outlet chute product detection**
- **Weighing unit (loss-in-weight / regulation)**
- **Dust collecting system**
- **Dedusting hood**

Metering conveyor type	Range of throughput*	Conveyor outer Ø
30	50 l/hr max.	40 mm
40	440 l/hr max.	50 mm
70	1 400 l/hr max.	76 mm
80	2 300 l/hr max.	89 mm
100	3 600 l/hr max.	104 mm
120	12 000 l/hr max.	140 mm

* the throughput can vary according to the product and the site design